

FIRST ANGLE PROJECTION

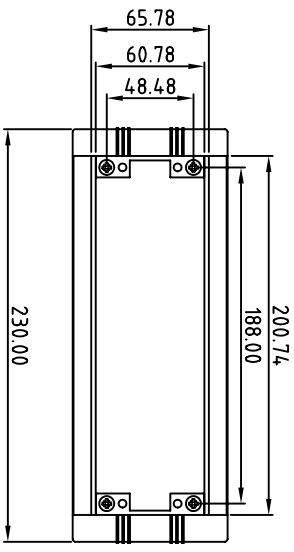
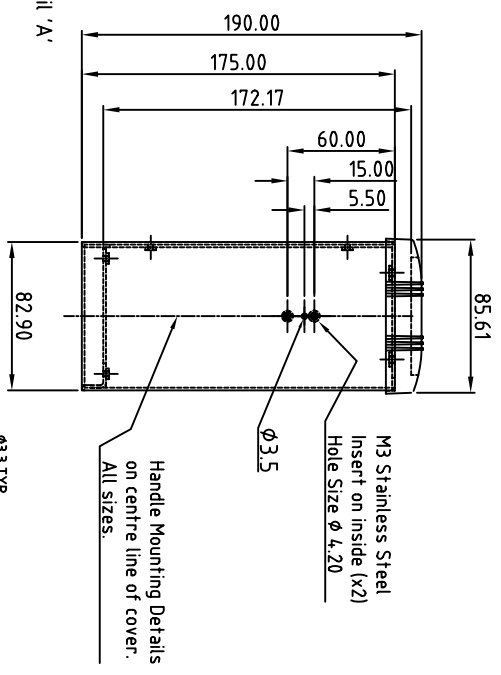
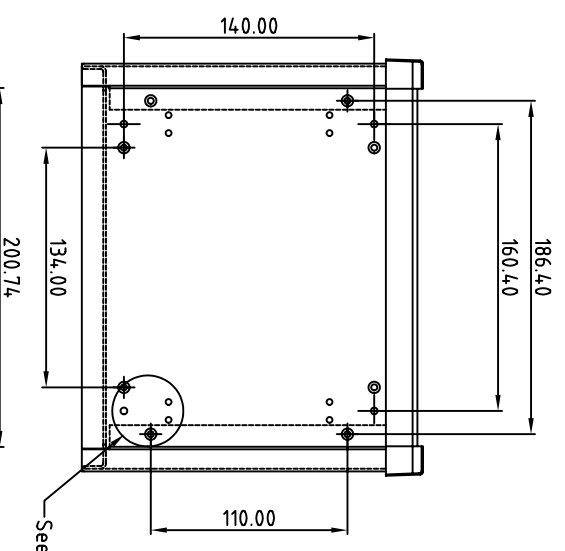
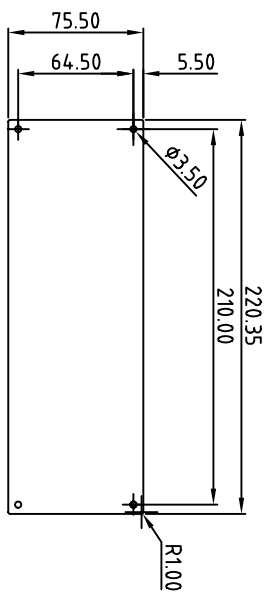
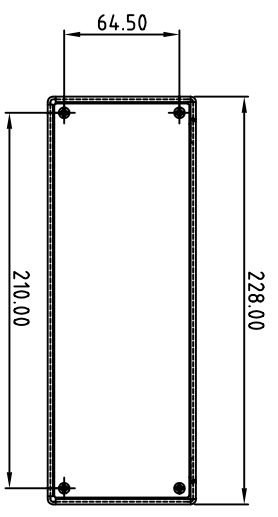

Note: Subject to technical modifications without prior notice.  
 Typographical and other errors do not justify any claim for damages.  
 All dimensions should be verified using the actual case.

Tolerances unless otherwise stated:

- General tolerances  $\pm 0.20$
- Resultant tolerances between hole centers  $\pm 0.15$
- Tolerances on hole diameters  $\pm 0.05$
- Angles  $\pm 0.5^\circ$
- Surface finish  $\sqrt{3.2}$

ALL DIMENSIONS IN MILLIMETRES

DO NOT SCALE

Required Finish	Scale	1:4	Checked By:	ALL DIMENSIONS IN MILLIMETRES		Date drawn	August '05	Material Spec.
	Drawn by:	Ian Cox	Drawing Number	M5623125	Part Name	UNIMET 2H	Sheet 1 of 1	



METCASE ENCLOSURES  
 Unit 3, Mitchell Close  
 Segensworth East, Fareham,  
 Hampshire, PO15 5SE, UK

www.metcase.com  
 Part Number  
 M5623125

©ORKW ENCLOSURES LTD. DATE AS SHOWN. THIS DRAWING CONTAINS PROPRIETARY INFORMATION OF ORKW ENCLOSURES LTD AND IS TENDERED SUBJECT TO THE FOLLOWING CONDITIONS: THE INFORMATION BE RETAINED IN CONFIDENCE, NOT BE REPRODUCED OR COPIED, AND NOT BE USED OR INCORPORATED IN ANY PRODUCT, UNLESS PERMISSION IS OBTAINED IN WRITING FROM ORKW ENCLOSURES LTD.