

FIRST ANGLE PROJECTION

Note: Subject to technical modifications without prior notice.  
 Typographical and other errors do not justify any claim for damages.  
 All dimensions should be verified using the actual case.

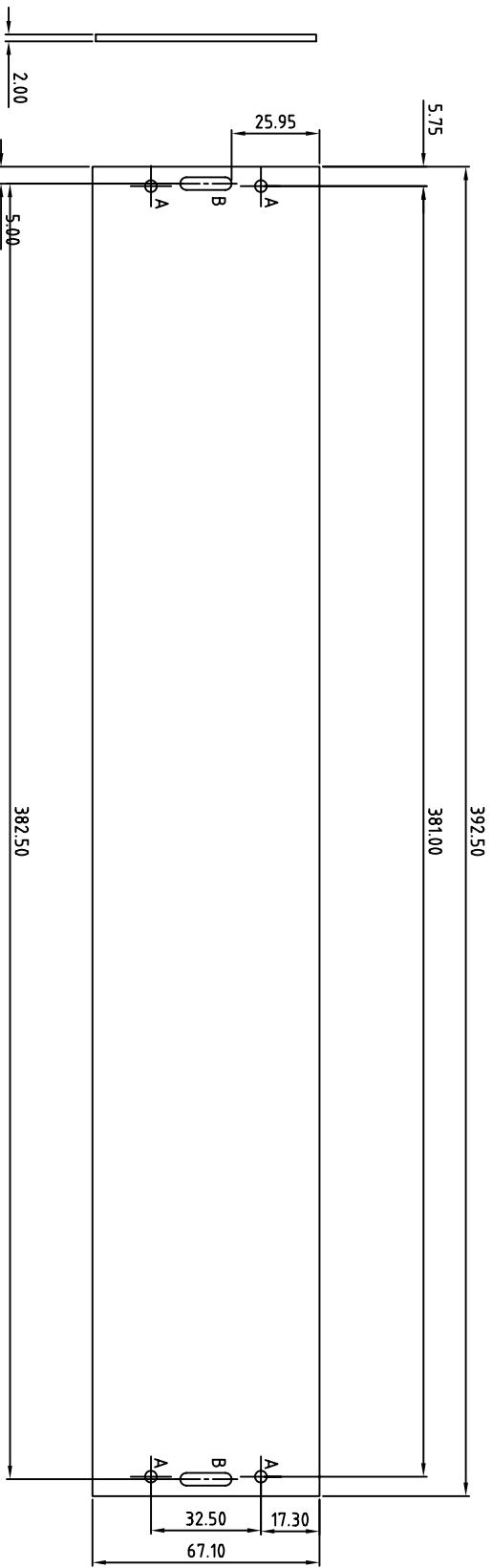

R188TYP DETAIL 'B' (4:1)

HOLES  
 A =  $\phi$ 4.0mm

- NOTES:
1. ALL PANELS TO BE CUT FROM SHEET SUCH THAT THE METAL GRAIN RUNS HORIZONTALLY
  2. PANELS MUST BE SHEARED FROM THE SAME SIDE.
  3. EDGES MUST BE CLEAN AND FREE FROM BURRS OR TOOL WITNESSES.
  4. PANEL FACES MUST BE SCRATCH FREE.
  5. HANDLE WITH CARE DURING MANUFACTURE.
  6. PANELS ARE TO SUPPLIED WRAPPED IN PROTECTIVE PAPER.

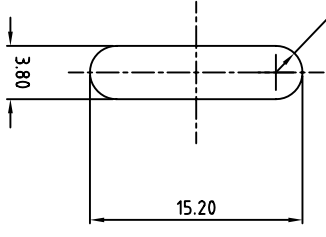

Tolerances unless otherwise stated:

General tolerances  $\pm 0.20$   
 Resultant tolerances between hole centers  $\pm 0.15$   
 Tolerances on hole diameters  $\pm 0.05$   
 Angles  $\pm 0.5^\circ$   
 Surface finish  $32\sqrt{\text{ }}$

Required Finish

Scale 1:2

ALL DIMENSIONS IN MILLIMETRES

Date drawn August '05

DO NOT SCALE

Drawn by Ian Cox

Checked by

Drawing Number M5900020

Part Name

2U (2HE) Front Panel Kit

Material Spec

**METcase**

METCASE ENCLOSURES  
 Unit 3, Mitchell Close  
 Segensworth East, Fareham,  
 Hampshire, PO15 5SE, UK.

Part Number

M5900020

Sheet 1 of 1

www.metcase.com

ORKW ENCLOSURES LTD. DATE AS SHOWN. THIS DRAWING CONTAINS PROPRIETARY INFORMATION OF ORKW ENCLOSURES LTD AND IS TENDERED SUBJECT TO THE FOLLOWING CONDITIONS: THE INFORMATION BE RETAINED IN CONFIDENCE, NOT BE REPRODUCED OR COPIED, AND NOT BE USED OR INCORPORATED IN ANY PRODUCT, UNLESS PERMISSION IS OBTAINED IN WRITING FROM ORKW ENCLOSURES LTD.

A4